



1

REPUBLIKA HRVATSKA
BRODSKO-POSAVSKA ŽUPANIJA
GRAD NOVA GRADIŠKA
Upravni odjel za gospodarstvo
Odsjek za upravljanje imovinom Grada

Nova Gradiška, 10.06.2016.god

KATALOG POSLOVNIH PROSTORA U VLASNIŠTVU GRADA NOVA GRADIŠKA 2016.



GRAD NOVA GRADIŠKA, Upravni odjel za gospodarstvo
Trg kralja Tomislava 1, 35400 Nova Gradiška
Tel.: +385 (0) 35 366-097 Fax: +385 (0) 35 366-089 GSM: 091 362 0106
E-mail: tomislavsigurnjak@novagradiska.hr, www.novagradiska.hr

1. POSLOVNI PROSTOR – KARLA DIENEŠA 2-prizemlje
kč.br. 1854 zk.ul.br.5118 K.O. Nova Gradiška
Površina 42,32m²
Kpelo dgpg

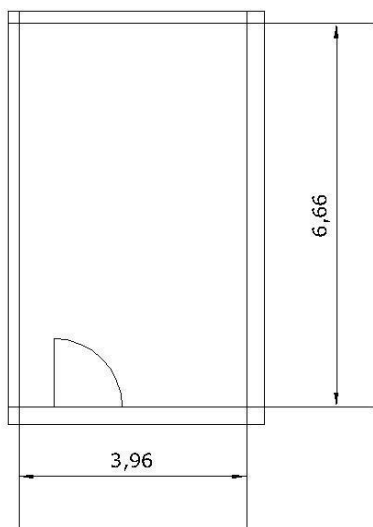

2. POSLOVNI PROSTOR – KARLA DIENEŠA 2-prizemlje
kč.br. 1854 zk.ul.br.5118 K.O. Nova Gradiška
Površina 34,50m²
Kpelo nppq

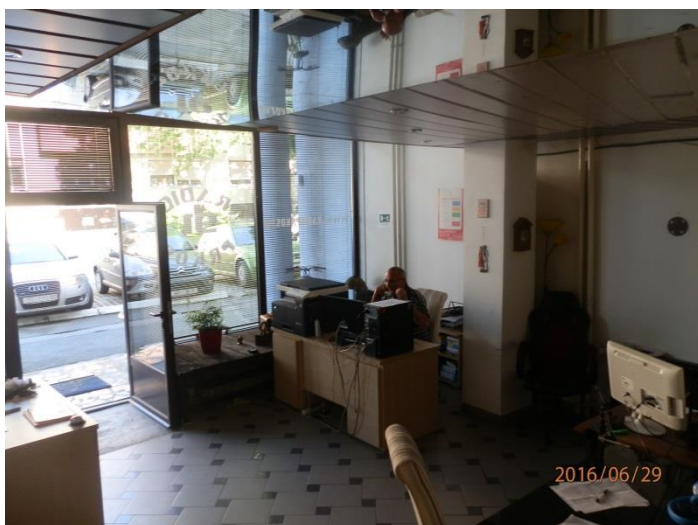
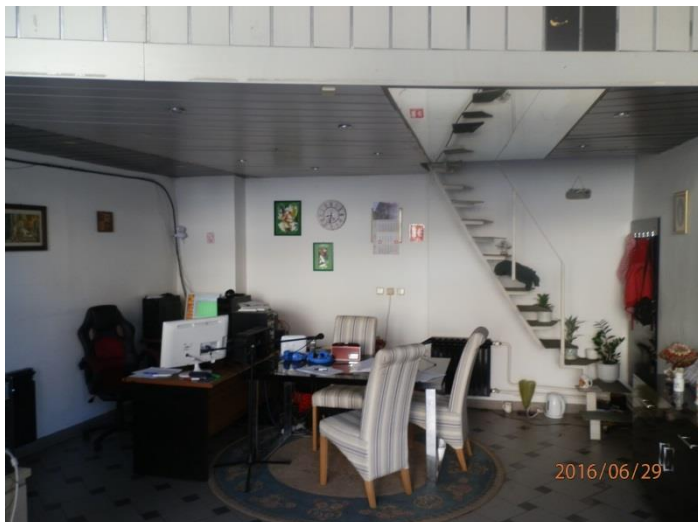
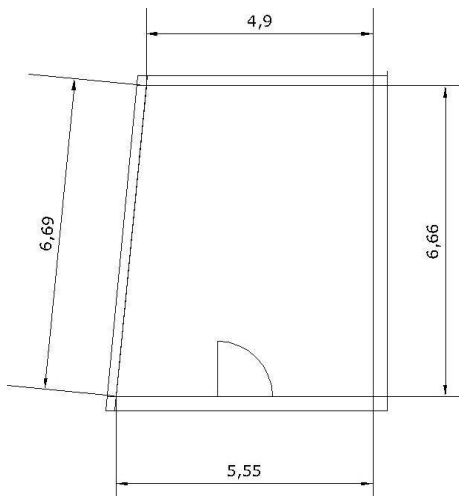

3. POSLOVNI PROSTOR – KARLA DIENEŠA 4-prizemlje
kč.br. 1855/1 zk.ul.br.4934 poduložak 4. K.O. Nova Gradiška
Površina 121,19m² + skladište 32,19m² na kč.br.1904/1-izvanknjižno vlasništvo
Kpelo dgpq

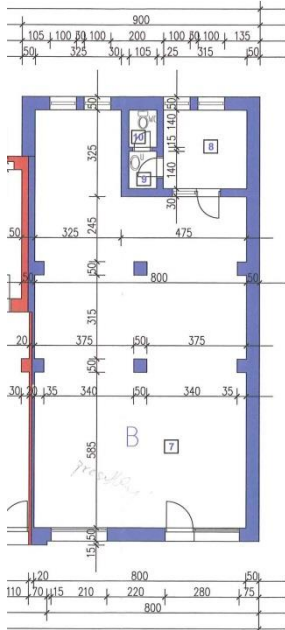

4. POSLOVNI PROSTOR – KARLA DIENEŠA 4-prizemlje
kč.br. 1855/1 zk.ul.br.4934 poduložak 6. K.O. Nova Gradiška
Površina 46,68m²
Kpelo dgpq

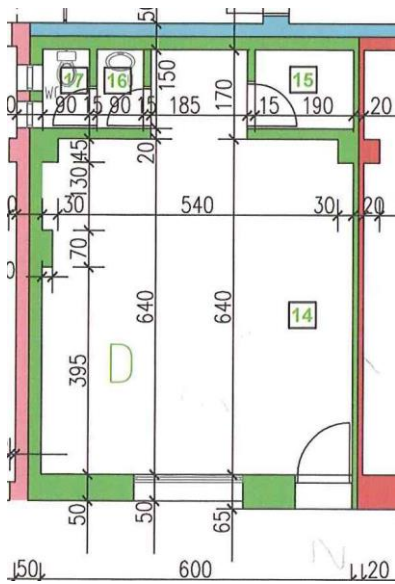

5. POSLOVNI PROSTOR – LJUDEVITA GAJA 9 - prizemlje
 kč.br. 2253/1 zk.ul.br.4831 poduložak 2. K.O. Nova Gradiška
 Površina 45,46m²
 Kpelo dgpg

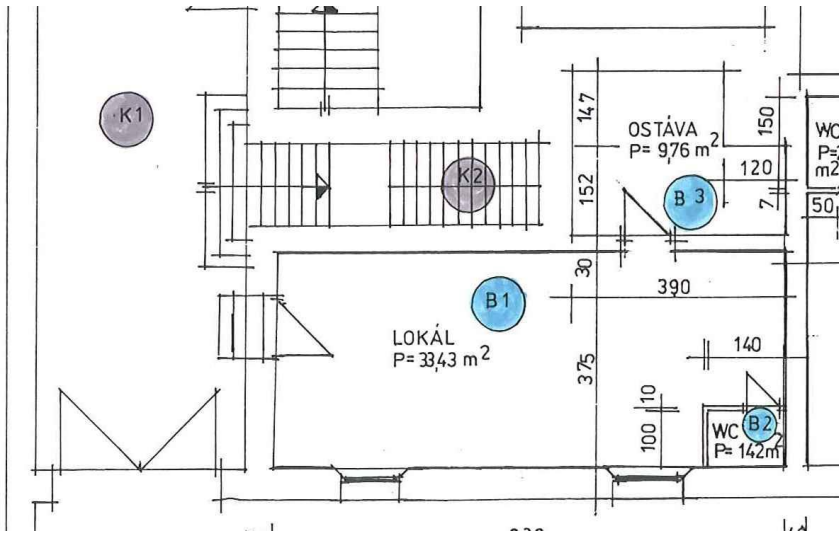

6. POSLOVNI PROSTOR – LJUDEVITA GAJA 9 - prizemlje
 kč.br. 2253/1 zk.ul.br.4831 poduložak 2. K.O. Nova Gradiška
 Površina 73,93m² (u funkciji
 Zakupnik: prazan

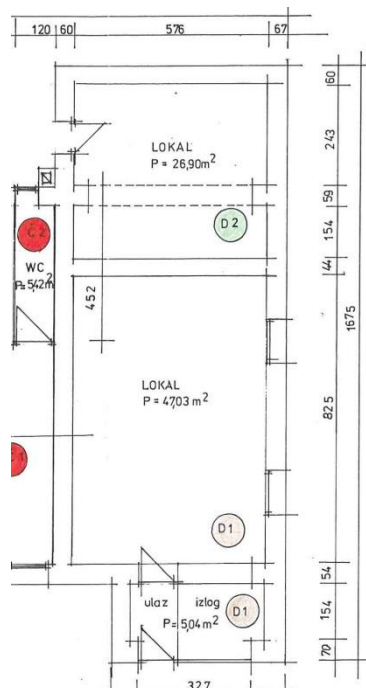

7. POSLOVNI PROSTOR – LJUDEVITA GAJA 9 - podrum
kč.br. 2253/1 zk.ul.br.4831 poduložak 2. K.O. Nova Gradiška
Površina 183,16m²
Zakupnik: prazan

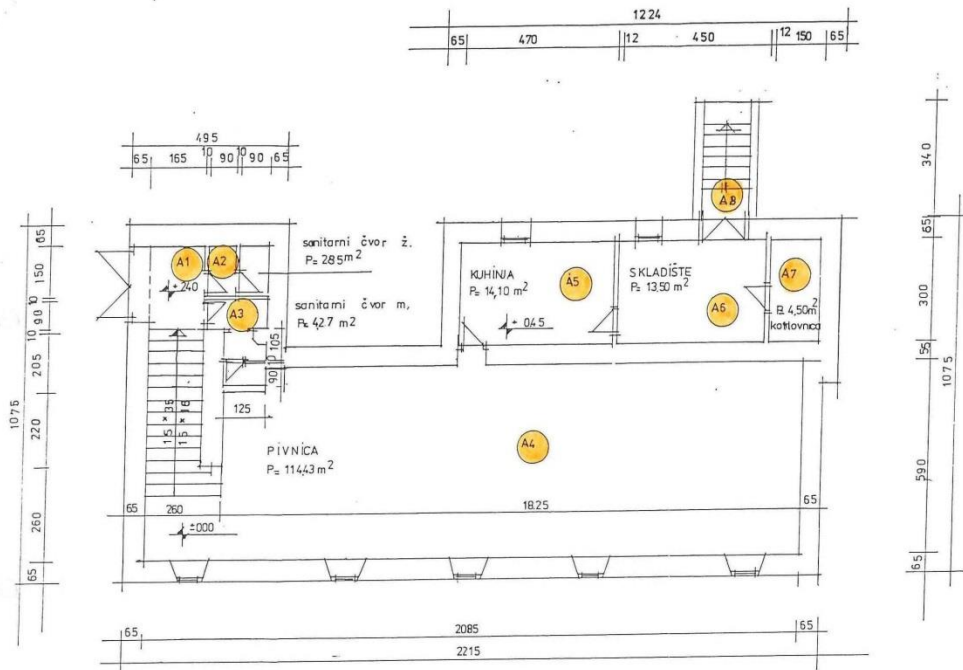

8. POSLOVNI PROSTOR – ALOJZIJA STEPINCA 2 – prizemlje i podrum
kč.br. 2249/2 zk.ul.br.4830 K.O. Nova Gradiška
Zakupnik: prazan



PRIZEMLJE poduložak 12.
Površina 246,59m²

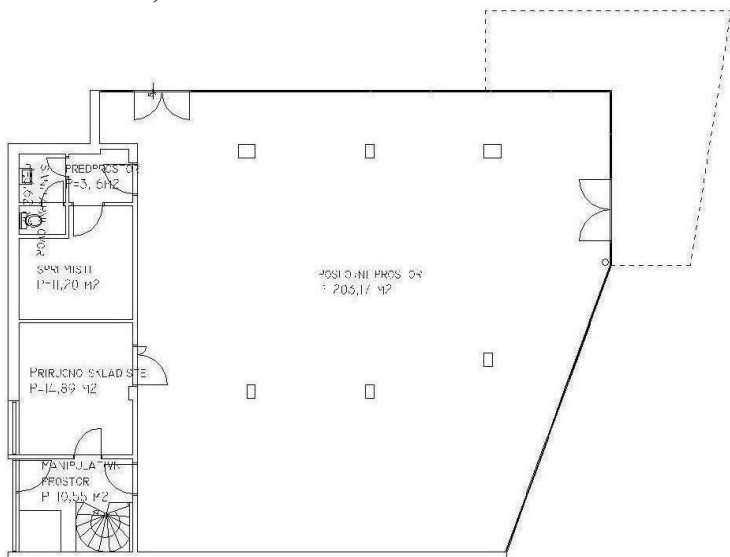

PODRUM poduložak 1.
Površina 100,71m²

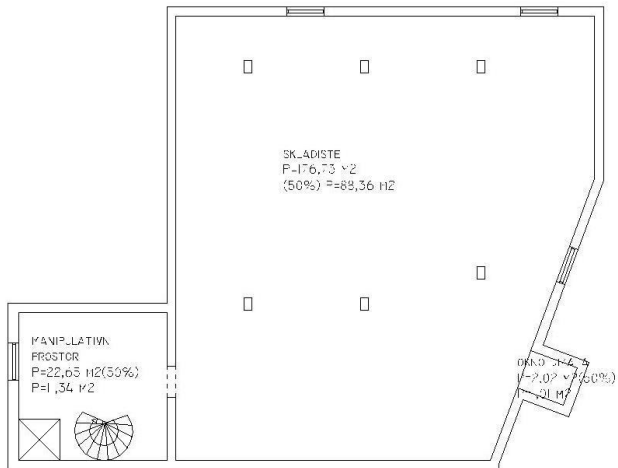

9. POSLOVNI PROSTOR – SLAVONSKIH GRANIČARA 1 – prizemlje
drugi s istočne strane
kč.br. 1849 zk.ul.br.5052 poduložak 2. K.O. Nova Gradiška
Površina 85m²
Кррclo ngrpq

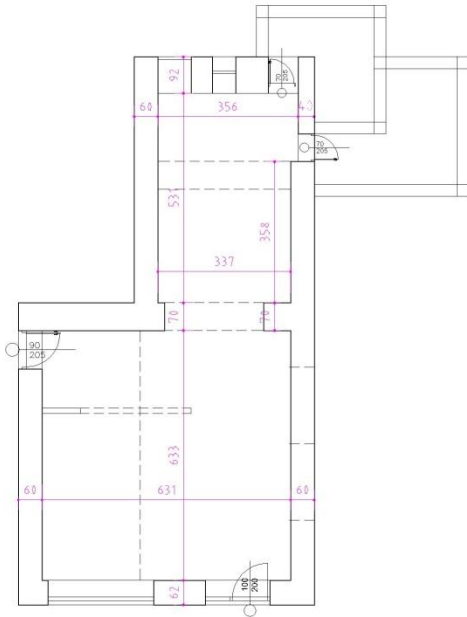

10. POSLOVNI PROSTOR – SLAVONSKIH GRANIČARA 1 – prizemlje

prvi sa zapadne strane

kč.br. 1849 zk.ul.br.5052 poduložak 1. K.O. Nova Gradiška

Površina 188m²

Kpelo nppq

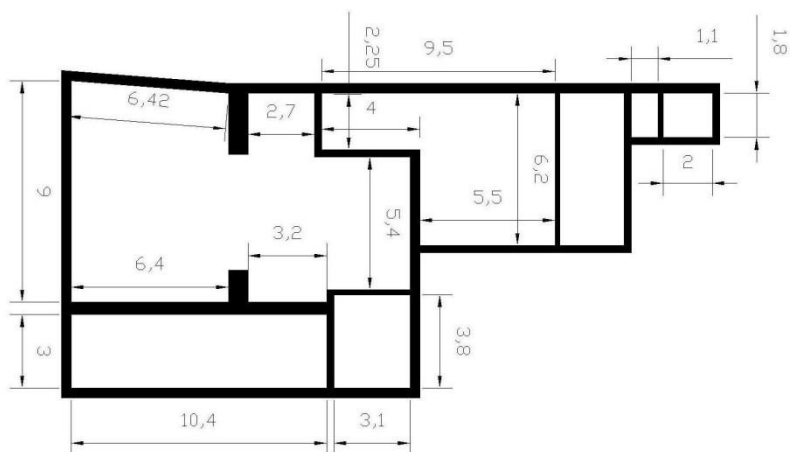
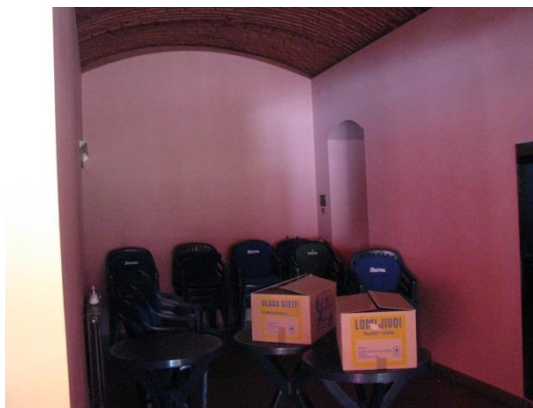

11. POSLOVNI PROSTOR – SLAVONSKIH GRANIČARA 1 – prizemlje
prvi sa istočne strane
kč.br. 1849 zk.ul.br.5052 poduložak 3. K.O. Nova Gradiška
Površina 48m²
Kpelo dgpg

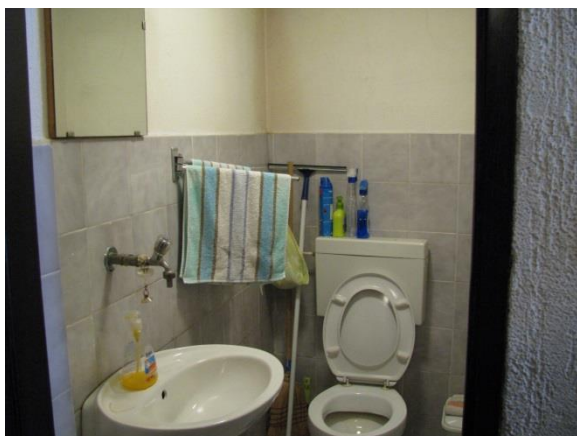
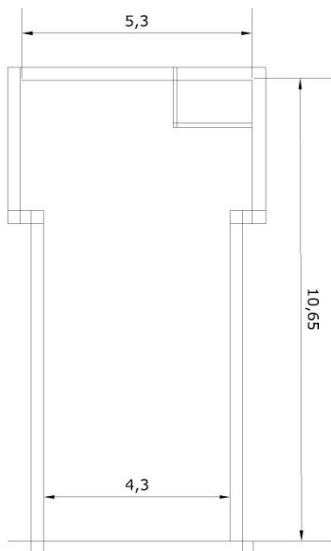

12. POSLOVNI PROSTOR – SLAVONSKIH GRANIČARA 3 – prizemlje
sa istočne strane dvorišta
kč.br. 1849 zk.ul.br.5052 poduložak 143. K.O. Nova Gradiška
Površina 155m²
Zakupnik: prazan – djelomično devastiran

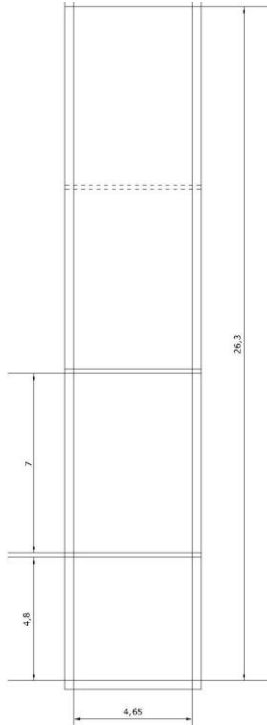

13. POSLOVNI PROSTOR – SLAVONSKIH GRANIČARA 7 – prizemlje
prvi sa zapadne strane
kč.br. 1845 zk.ul.br.3880 nije etažiran. K.O. Nova Gradiška
Površina 128m²
Крццо дгпц

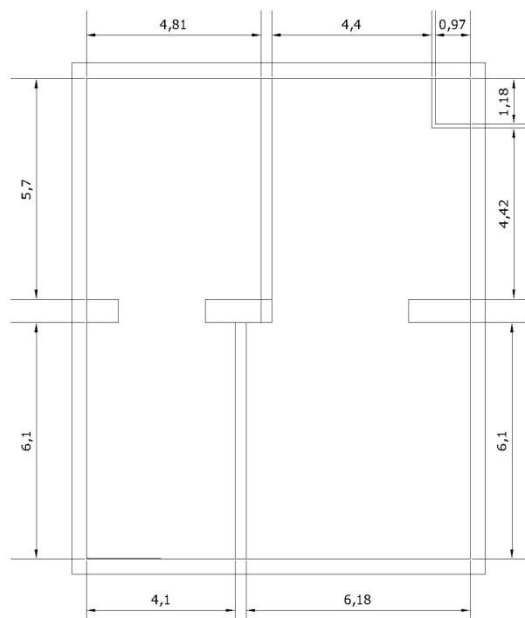

14. POSLOVNI PROSTOR – SLAVONSKIH GRANIČARA 7 – prizemlje
prvi sa istočne strane
kč.br. 1845 zk.ul.br.3880 nije etažiran. K.O. Nova Gradiška
Površina 57,74m²
Kpelo dgpg

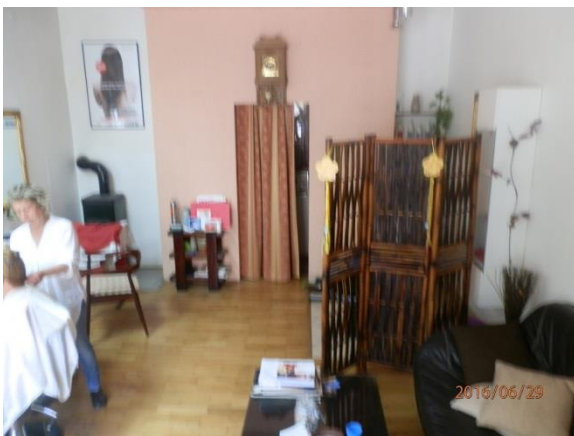
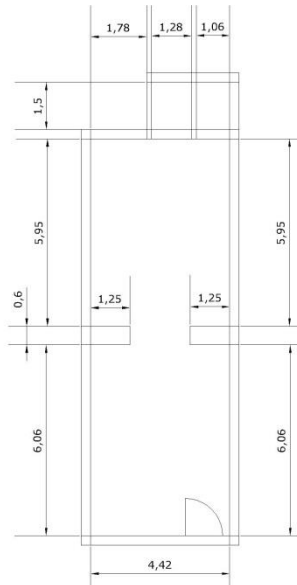

15. POSLOVNI PROSTOR – SLAVONSKIH GRANIČARA 7 – prizemlje
drugi sa istočne strane
kč.br. 1845 zk.ul.br.3880 nije etažiran. K.O. Nova Gradiška
Površina 64,00m²
Iznajmljeno

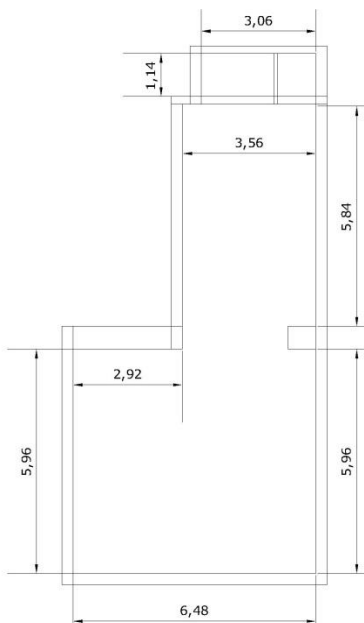

**16. POSLOVNI PROSTOR – SLAVONSKIH GRANIČARA 7/1 – prizemlje
u dvorištu – prvi s juga -lijevo
kč.br. 1845 zk.ul.br.3880 nije etažiran. K.O. Nova Gradiška
Površina 49,98m²
Iznajmljeno**

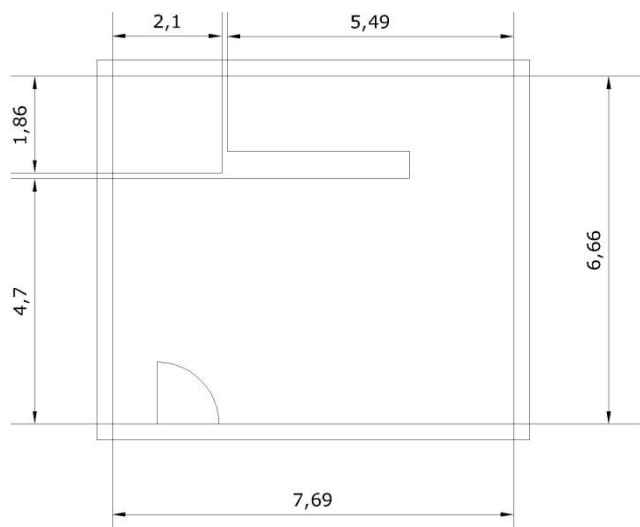

17. POSLOVNI PROSTOR – SLAVONSKIH GRANIČARA 7/1 – prizemlje
u dvorištu – drugi s juga - lijevo
kč.br. 1845 zk.ul.br.3880 nije etažiran. K.O. Nova Gradiška
Površina 43m²
Zakupnik: prazno

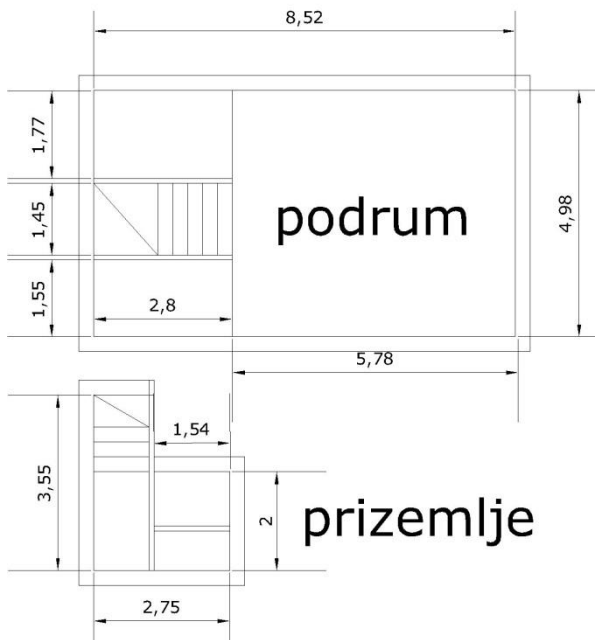

18. POSLOVNI PROSTOR – SLAVONSKIH GRANIČARA 7/1 – prizemlje
u dvorištu – treći s juga - lijevo
kč.br. 1845 zk.ul.br.3880 nije etažiran. K.O. Nova Gradiška
Površina 27,48m²
Zakupnik: prazno

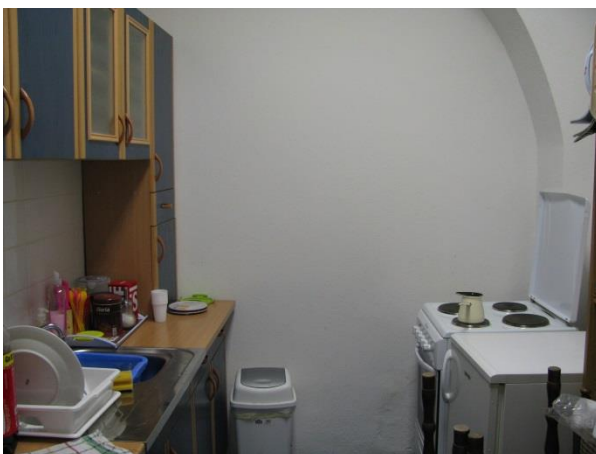
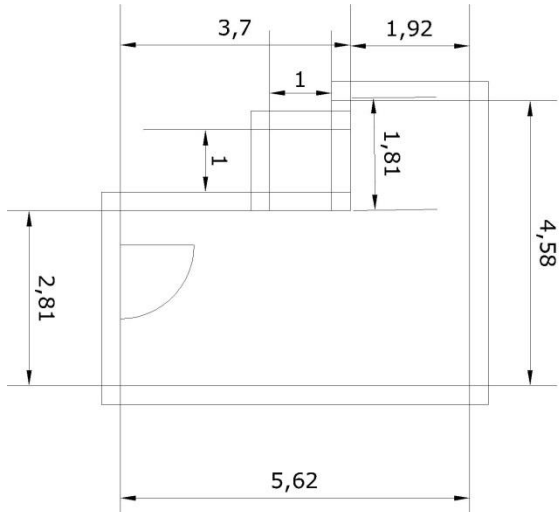

19. POSLOVNI PROSTOR – SLAVONSKIH GRANIČARA 7/1 – prizemlje
u dvorištu – četvrti s juga - lijevo
kč.br. 1845 zk.ul.br.3880 nije etažiran. K.O. Nova Gradiška
Površina 17,00m²
Iznajmljeno

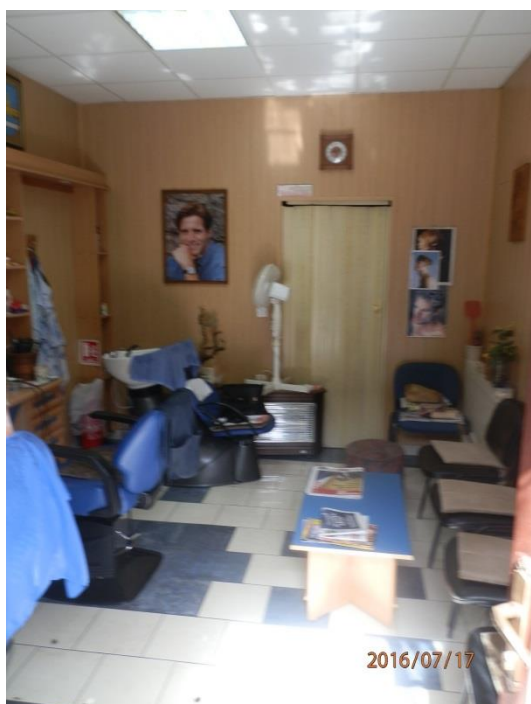
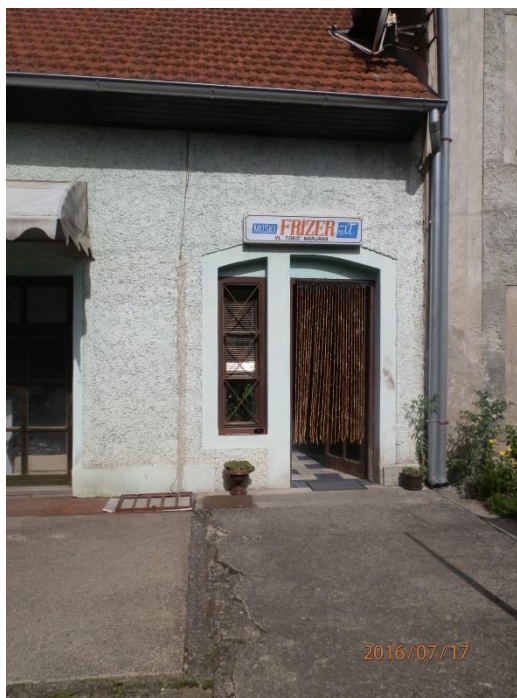
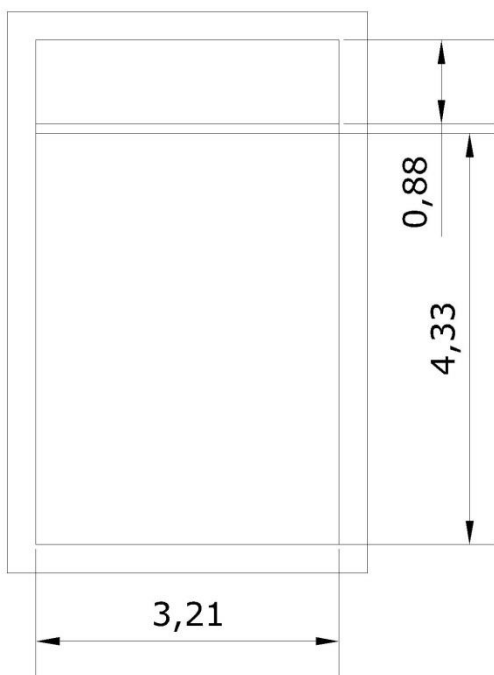

20. POSLOVNI PROSTOR – SLAVONSKIH GRANIČARA 7/1 – prizemlje
u dvorištu - desno
kč.br. 1845 zk.ul.br.3880 nije etažiran. K.O. Nova Gradiška
Površina 27,47m²
Zakupnik: prazno

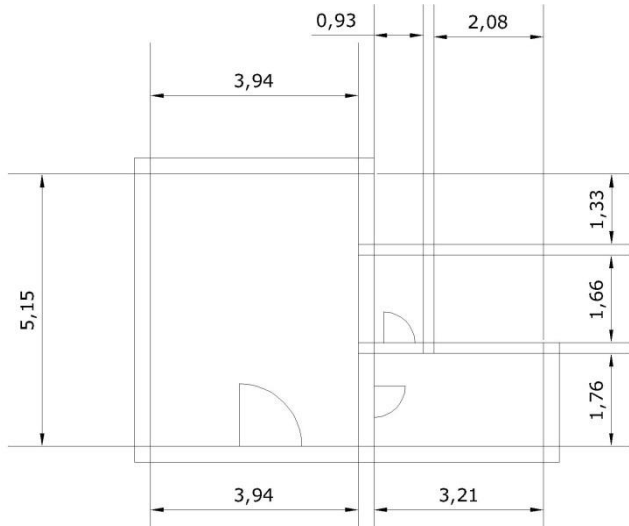

21. POSLOVNI PROSTOR – SLAVONSKIH GRANIČARA 15 – prizemlje
u dvorištu - desno
kč.br. 1845 zk.ul.br.3880 nije etažiran. K.O. Nova Gradiška
Površina 58,50m²
Iznajmljeno

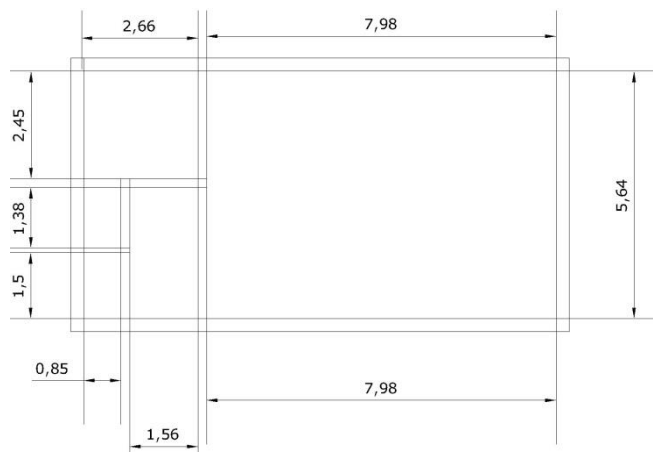

22. POSLOVNI PROSTOR – IVANA GUNDULIĆA 15A – prizemlje
kč.br. 2344/5 zk.ul.br.4374 poduložak 2. K.O. Nova Gradiška
Površina 32,41m²
Iznajmljeno

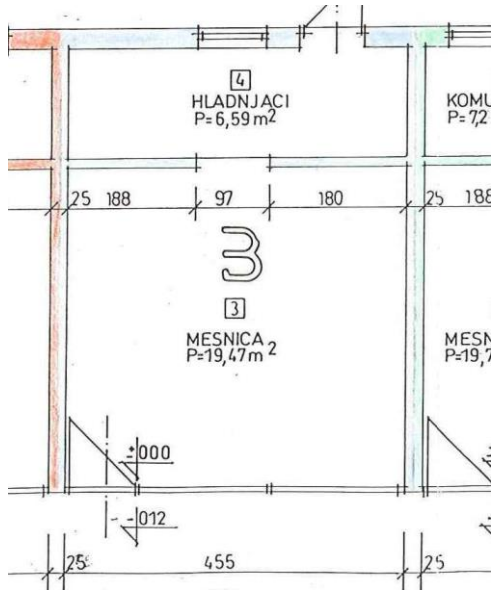

23. POSLOVNI PROSTOR – IVANA GUNDULIĆA 15A – prizemlje
kč.br. 2344/1 zk.ul.br.4375 poduložak 8. K.O. Nova Gradiška
Površina 23,22m² - fizički spojen s prostor u vlasništvu Slavče d.o.o.
Iznajmljeno

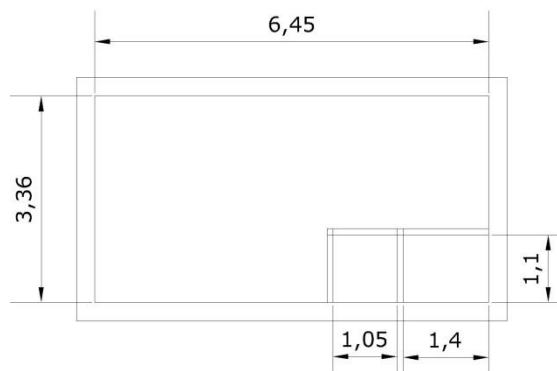

Skica-prema elab. etažiranja

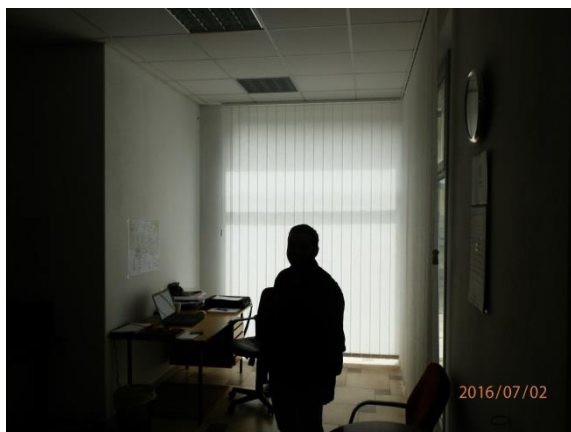

Fotografije – spojenih poslovnih prostora

24. POSLOVNI PROSTOR – IVANA GUNDULIĆA 15A – I kat
kč.br. 2344/1 zk.ul.br.4375 poduložak 15. K.O. Nova Gradiška
Površina 70m²
Iznajmljeno

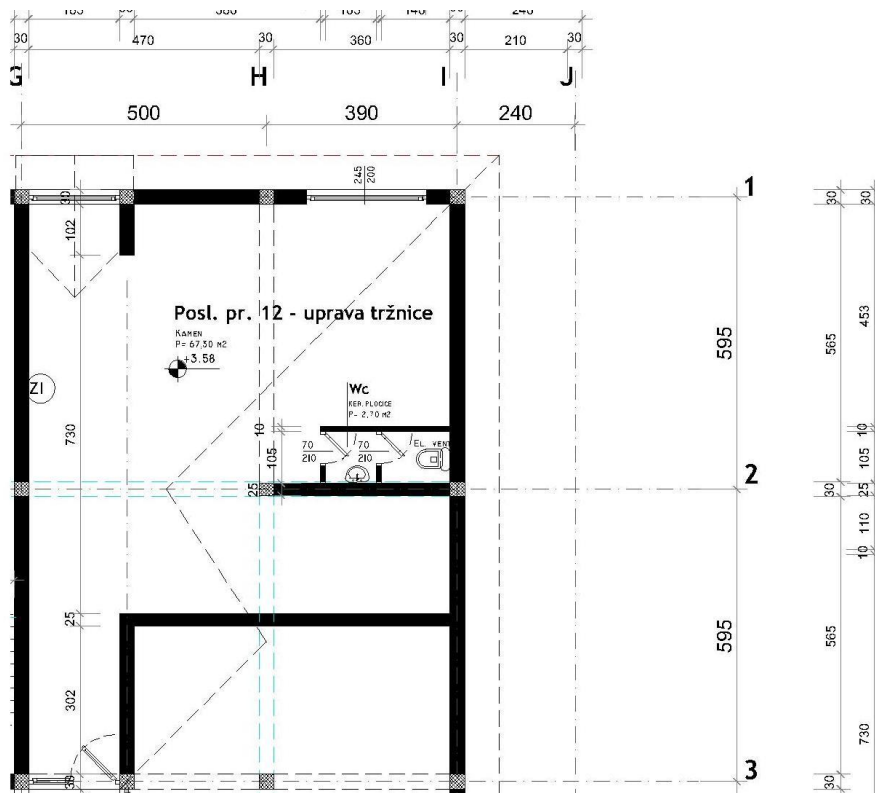

25. POSLOVNI PROSTOR – M.A.Relkovića – prizemlje i podrum
kč.br. 2308 zk.ul.br.4840 poduložak 1. K.O. Nova Gradiška
Površina 71,60m²
Iznajmljeno

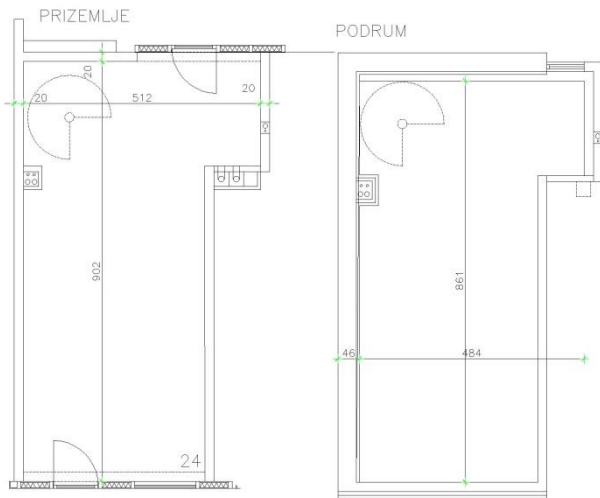

26. POSLOVNI PROSTOR – Trg dr. Franje Tuđman 1 – prizemlje
kč.br. 2304/9 zk.ul.br.3700 - nije etažirano- K.O. Nova Gradiška
Površina 84,68m²
Iznajmljeno

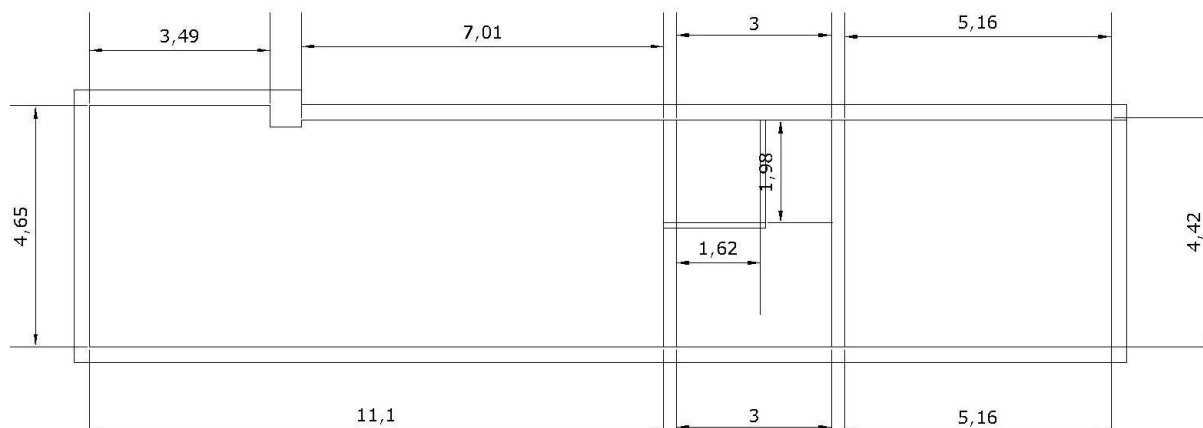

27. POSLOVNI PROSTOR – Ulica Zrinski 4 – prizemlje
kč.br. 2251 zk.ul.br. 3881 – nije etažirano - K.O. Nova Gradiška
Površina 129,70m²
Zakupnik: prazno

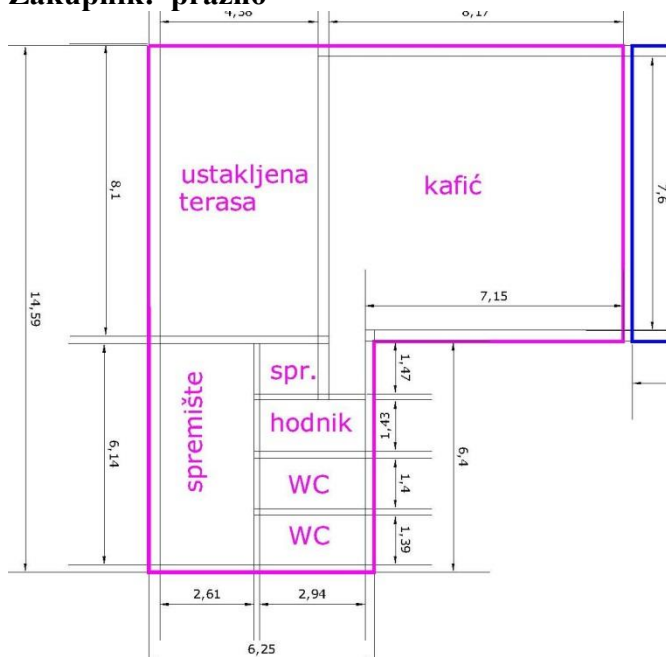

28. POSLOVNI PROSTOR – Gajeva 14 – prizemlje
kč.br. 1922 K.O. Nova Gradiška- izvanknjižno vlasništvo
Površina 163,16m²
Iznajmljeno

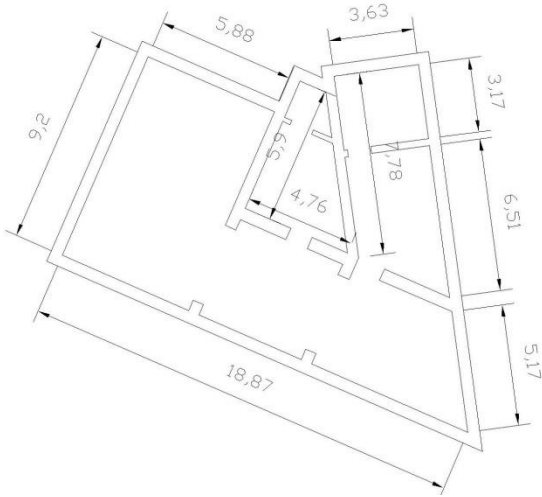

30. POSLOVNI PROSTOR – Trg kralja Tomislava 5 – prizemlje
treći s južne strane
kč.br. 2251 zk.ul.br. 3881 – nije etažirano - K.O. Nova Gradiška
Površina 106,00m²
Iznajmljeno

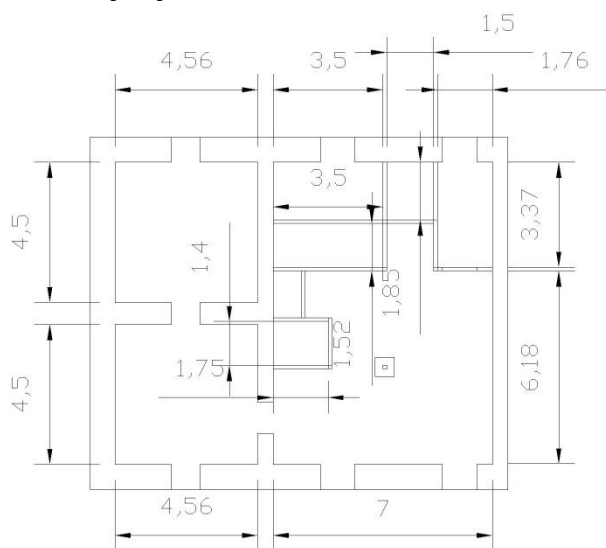

31. POSLOVNI PROSTOR – Trg kralja Tomislava 5 – prizemlje
čtvrť s južne strane
kč.br. 2251 zk.ul.br. 3881 – nije etažirano - K.O. Nova Gradiška
Površina 13,95m²
Iznajmljeno

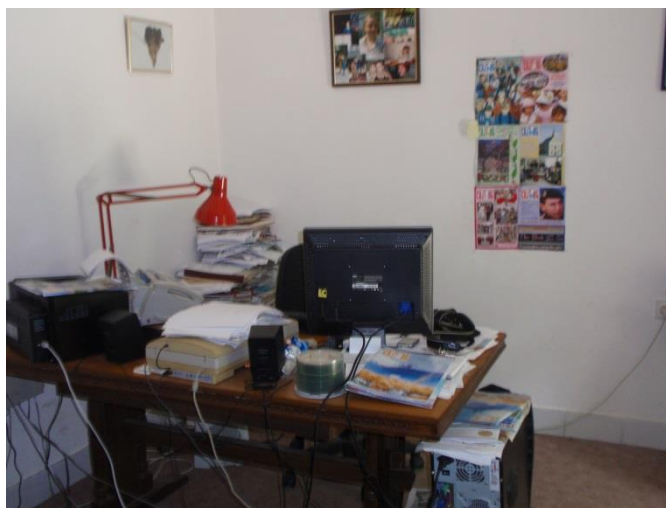
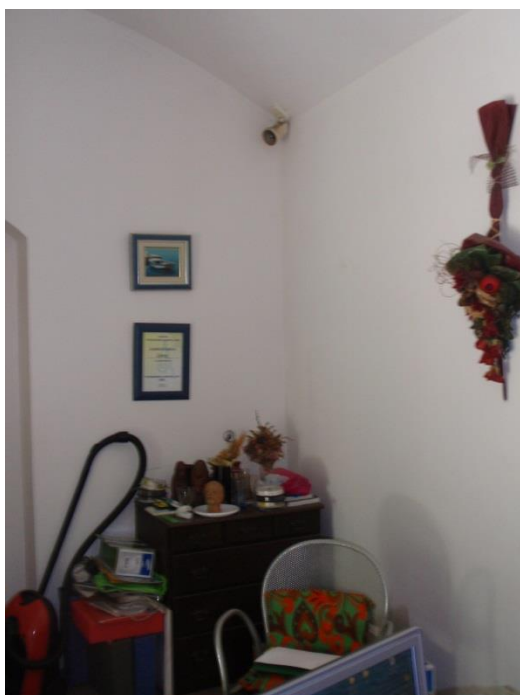
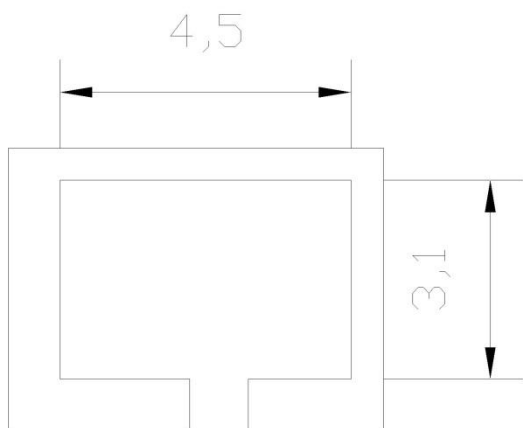

**32. POSLOVNI PROSTOR – Trg kralja Tomislava 5 – prizemlje
drugi s sjeverne strane
kč.br. 2251 zk.ul.br. 3881 – nije etažirano - K.O. Nova Gradiška
Površina 19,07m² - s udubljenjim u zidovima koji nisu prikazani na skici
Iznajmljeno**

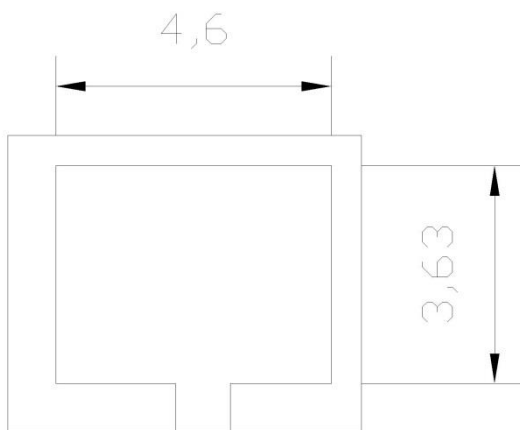

33. POSLOVNI PROSTOR – Gajeva 14 – prizemlje
kč.br. 1907 zk.ul.br. 4989 pouložak 1 K.O. Nova Gradiška- vlasništvo Republike Hrvatske
Površina 126,00m²
Iznajmljeno

